



P.O. Box 247, 4320 Aerotech Center Way
 Paso Robles, CA 93447
 Telephone: (800) 350-2223 Fax: (805) 238-4201
 PAGE 1 OF 13 Page Rev. Date: 06-12-20
 P/N: RUBI-JKAD

RUBICRAWLER JEEP JK with HD T/C CABLE (2007-2011)

KIT CONSISTS OF:

No.	Qty	Part No.	Description
1.	1	RUBICRAWLER	GEAR BOX
2.	1	42R800	CONTROL MODULE KIT
3.	1	42R-J	JEEP JK SHIFTER KIT

Optional Items:

Part No.	Description
42R360	-CHRYSLER ATF+4 (Qty. 4 Recommended)

Kit Includes:

1.	1	29-2004	NUT-REAR YOKE NUT FOR JEEP ROCKTRAC
2.	4	303081	BUSHING - IGUS 1/2" X 1/2"
3.	1	303121	NUT-1/2-13 HX JAM BLACK ZINC
4.	1	303309-1	CABLE-ATLAS SHIFTER 48" LENGTH 1" TRAVEL
5.	4	303313	ROD END- FEMALE 1/4"-28
6.	2	303335	KNOB MOUNT-CABLE SHIFTER TJ
7.	4	303339	BOLT- 1/4"-28 X .75" F.H.C.S.
8.	2	303341	BOLT- 1/4"-28 X 5/8" B.H.C.S.
9.	1	42R320	BRACKET- RUBICRAWLER FOOT MOUNT JK
10	1	42R441	BRACKET - RUBICRAWLER CABLE MOUNT
11	1	42R580	BRACKET -JK FUEL LINE SUPPORT
12	1	42R581	NUT CLIP ON 6MM
13	1	42R582	S.H.C.S. 6MM-1.00 X 8 MM LONG
14	1	42R600	BRACKET -JK SHIFT BASE PLATE
15	1	42R601	BRACKET - PIVOT MOUNT
16	1	42R603	HANDLE ASSEMBLY-JK PASSENGER
17	1	42R608	BARREL-CABLE
18	1	42R609	SPRING- WAVE
19	1	42R610	BRACKET - BARREL RETAINER
20	1	42R611	SHAFT-JK PIVOT
21	9	42R616	BOLT- 1/4"-20 X 5/16" B.H.C.S.
22	2	42R617	BOLT- 1/4"-20 X 3/8" B.H.C.S. PLAIN
23	1	42R618	BOLT- 5/16"-18 X 3.25" H.H.C.S.
24	1	42R620	BRACKET- OEM JK T-CASE SHIFTER
25	1	42R651	KNOB-JK RUBICRAWLER
26	1	42R652	KNOB-JK T-CASE
27	1	42R672	HANDLE ASSEMBLY-JK DRIVER
28	1	42R673	BRACKET - JK INTERIOR
29	1	42R725-1	SHIFTER CABLE- 2" TRAVEL
30	2	42R726	HEAT SHIELD- FIREPROOF SLEEVE
31	1	42R735	BOLT- 1/4"-20 X 1" H.H.C.S. GRD 8
32	1	42R740	BOLT 8MM X 1.25 X 14MM H.H.C.S.
33	1	715596C	LEVER-TRANSFER CASE
34	1	715596E	SPACER-TRANSFER CASE LEVER
35	2	720040	S.H.C.S. 8MM X 1.25 X 20MM
36	4	720057	6MM X 1 X 16MM HHCS GRD 8.8
37	1	722512	F.H.C.S. 1/4"-20 X 1" LG PLAIN
38	4	722513	LOCKWASHER 1/4" PLT.
39	2	722514	NYLON LOCKNUT 1/4"-20
40	7	722523	1/4" USS FLAT WASHER PLTD.
41	1	722543	1/4" X 20" X 1-1/2" S.H.C.S. PLAIN
42	1	723141	5/16"-18 NYLOC HEX NUT
43	2	723740	3/8"-16 X 1-1/2" S.H.C.S.
44	1	42R350	SEALANT ATF RTV
45	1	42R540	BOLT M10 X 1.5 X 30 BHCS
46	4	720015	10MM FLAT WASHER
47	10	720028	10MM -1.5X 35MM SHCS
48	4	720073	10MM-1.5 X 25 MM FLANGE BOLT

SPECIAL NOTE: The components packaged in this kit have been assembled and machined for specific type of conversions. Modifications to any of the components will void any possible warranty or return privileges. If you do not fully understand modifications or changes that will be required to complete your conversion, we strongly recommend that you contact our sales department for more information. This instruction sheet is only to be used for the assembly of Advance Adapter components. We recommend that a service manual pertaining to your vehicle be obtained for specific torque values, wiring diagrams and other related equipment. These manuals are normally available at automotive dealerships and parts stores.

RUBICRAWLER JEEP JK with HD T/C CABLE (2007-2011)

These are the bottom 12 items listed under the shifter kit components on the first page. These items do need to be assembled.

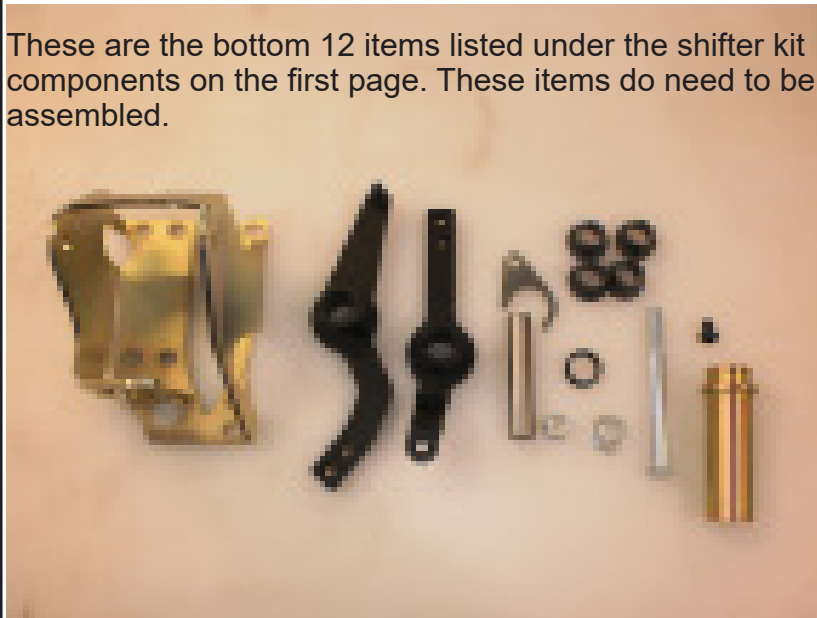

The Igus bushings must be **pressed** into the shift handles. An arbor press or a light hand with a hammer works well. Once the bushings are installed the pivot pin gets installed through the handles with the wave washer between them.

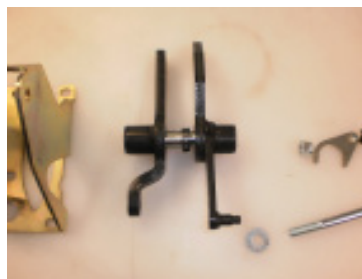

Install the handles into the bracket housing and install the bolt to secure the assembly in place. Install the cable barrel and use the retainer clip to hold in place.



SPECIAL NOTE: The components packaged in this kit have been assembled and machined for specific type of conversions. Modifications to any of the components will void any possible warranty or return privileges. If you do not fully understand modifications or changes that will be required to complete your conversion, we strongly recommend that you contact our sales department for more information. This instruction sheet is only to be used for the assembly of Advance Adapter components. We recommend that a service manual pertaining to your vehicle be obtained for specific torque values, wiring diagrams and other related equipment. These manuals are normally available at automotive dealerships and parts stores.



P.O. Box 247, 4320 Aerotech Center Way
Paso Robles, CA 93447
Telephone: (800) 350-2223 Fax: (805) 238-4201
PAGE 3 OF 13 Page Rev. Date: 01-27-17
P/N: RUBI-JKAD

RUBICRAWLER JEEP JK with HD T/C CABLE (2007-2011)

Tool List:

1. FULL SET OF HAND TOOLS INCLUDING:
 - 6 mm ALLEN WRENCH
 - 16 mm DEEP SOCKET
 - 8mm HEX BIT SOCKET
 - 3/8" DRIVE RATCHET
 - 15/16" WRENCH
 - 5/32" ALLEN WRENCH
2. 3/8" TORQUE WRENCH
(25 TO 40 FT.-LBS. REQUIRED)
3. GASKET SCRAPER
4. SMALL BRASS WIRE BRUSH
5. CLEANING SOLVENT
(PAINT THINNER, ACETONE, MEK ETC) DO
NOT USE DEGREASERS LIKE SIMPLE GREEN
6. STUBBY 9/16" WRENCH REQUIRED,
RATCHETING RECOMMENDED.
7. T20, T30, AND T45 TORX BIT SOCKETS.
8. SLIDE HAMMER.

Note: on new installations if the transfer case is re-clocked up closer to the floor board, we have had customers complain of vibrations in the drivetrain. Clocking the transfer case changes the driveline angles, which creates a vibration and most think it is because of the new RubiCrawler. Re-clocking the transfer case from stock will require axle pinion angle adjustments.

SPECIAL NOTE: The components packaged in this kit have been assembled and machined for specific type of conversions. Modifications to any of the components will void any possible warranty or return privileges. If you do not fully understand modifications or changes that will be required to complete your conversion, we strongly recommend that you contact our sales department for more information. This instruction sheet is only to be used for the assembly of Advance Adapter components. We recommend that a service manual pertaining to your vehicle be obtained for specific torque values, wiring diagrams and other related equipment. These manuals are normally available at automotive dealerships and parts stores.

RUBICRAWLER JEEP JK with HD T/C CABLE (2007-2011)

Interior Disassembly:

1. Removing the driver's seat will make the interior install easier, but **PRECAUTION** needs to be taken. The seat must be handled with care as the seat weight sensor is a sensitive calibrated unit and can be damaged if dropped or sat on when not in the vehicle. To remove the seat, first disconnect the negative terminal of the battery and wait two minutes for the system capacitors to drain. Next disconnect the two electrical connectors below the seat and then the seat can be removed. Refer to the service manual for more information on removing the seat.
2. Remove the four T30 Torx bolts on the sides of the console, 2 on the driver's side and 2 on the passenger side (See *Figure 7*).
3. Remove the transmission shifter knob. Begin by grabbing the trim ring at the base of the shift knob and gently pull down while twisting it. Remove the Torx bolt with a T20 bit. The transmission shift knob can now be removed from the lever. (See *Figure 8*)
4. Remove the transfer case shift knob. You must grab firmly, twist & pull straight up until it pops off. A glove is recommended to protect your hand during this step, as the removal can sometimes be difficult.
5. Pull parking brake as far up as it will go.
6. Remove the lower dash panel by prying with a small flat head screw driver at the top of the panel until it pops loose and then slide it out. (See *Figure 9*)
7. Remove upper console by pulling up gently on the rear of it. It is held on with metal clips that will pop out as it is lifted up and removed. (See *Figure 10*)
8. Remove the lower console.
9. Remove the transfer case shifter housing top cover. (See *Figure 11*)
10. Remove the 4 mounting nuts that hold down the shifter housing with a 10mm socket. Save these nuts as they will be reused.
11. Turn the transfer case shifter housing on its side.
12. Remove the shifter rod end from the pin using 2 flat head screw drivers. (*Figure 12*)
13. Remove the shift housing from the shift cable by un-clipping the plastic cable mount and sliding it out. (See *Figure 13*)
14. Pull shift cable grommet down through floor and cut a slit to allow RubiCrawler cable to pass through on the passenger side. Note: cable will be installed in a later step.



Figure 7: Rear Bolt Location



Figure 8: Trim Ring



Figure 9: Lower Dash Panel



Figure 10: Remove Upper Console

Figure 11: Remove Shift Cable from Housing

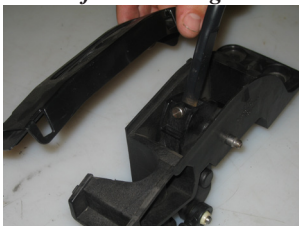
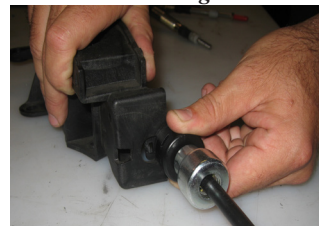

Figure 12: Rod End Removal



Figure 13: Transfer Case Shift Housing



RUBICRAWLER JEEP JK with HD T/C CABLE (2007-2011)

RubiCrawler Install:

Disassembly/Preparation For Assembly:

1. Remove drive shafts and any skid plates that prevent access to the transfer case or the transmission.
2. Disconnect the breather hose and the wiring harness from the transfer case.
3. As shown in *Figure 1*, using two flat head screw drivers remove the rod end from the transfer case.
4. Remove the transfer case from the vehicle by removing the 6 nuts from the transfer case studs. Using a stubby 9/16" wrench makes this step much easier.
5. Remove the transfer case shift cable from the bracket mounted to the tailhousing by squeezing the tabs on the orange plastic retaining clip and pulling down on the cable (Clip will not be reused). Then remove the three 10mm bolts securing the transfer case shifter bracket to the tailhousing.
6. Use a jack to support the transmission pan to support its weight. Take **caution** to avoid denting the pan and damaging the transmission.
7. Remove the foot-mount from the tailhousing of the transmission by unbolting the four 10 mm hex head bolts.
8. Unbolt the fuel system tab from the transmission tailhousing.
9. Remove the wiring harness from the tailhousing by prying up the plastic barb on the driver's side of tailhousing.
10. Remove the spud shaft by following one of the suggested methods below. The end of the spud shaft is tapped M10-1.5.
 - i. Slide Hammer -(factory service manual method): Note: aggressive use may be necessary.
 - ii. Custom Puller (recommended method)- Make a custom device to span the tailhousing without contacting the end of the shaft. Thread a M10x1.5 bolt through tool and into the spud shaft. (See *Figure 3*)
11. Prepare a drip pan. Removing the tailhousing will result in 2-4 quarts of transmission fluid loss depending on the angle of the drivetrain.
12. Remove the transmission tailhousing by removing the 11 hex head

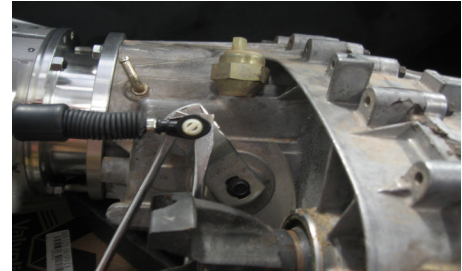

Figure 1: Rod End Removal



Figure 2: Uni-Raise installation aid



Figure 3: Custom Puller Method

SPECIAL NOTE: The components packaged in this kit have been assembled and machined for specific type of conversions. Modifications to any of the components will void any possible warranty or return privileges. If you do not fully understand modifications or changes that will be required to complete your conversion, we strongly recommend that you contact our sales department for more information. This instruction sheet is only to be used for the assembly of Advance Adapter components. We recommend that a service manual pertaining to your vehicle be obtained for specific torque values, wiring diagrams and other related equipment. These manuals are normally available at automotive dealerships and parts stores.

RUBICRAWLER JEEP JK with HD T/C CABLE (2007-2011)

bolts and allow oil to drain for 10 minutes.

13. Insert a CLEAN shop rag into the back of the transmission as shown in the picture below to prevent contaminants from entering your transmission. (See *Figure 5*)
14. Thoroughly clean the rear face of the transmission. Use solvent and a brass wire brush to clean all of the RTV off of the mating face and take caution to avoid any debris from entering the transmission or transmission bearing. (See *Figure 6*) It may be necessary to trim excess RTV that protrudes up from the transmission pan onto the rear face of the transmission. Excess RTV can prevent the RubiCrawler from fully mating to the transmission face.
15. Remove the spud shaft retaining clip from the groove near the end of the transmission output shaft.
1. Remove the red plug and O-ring, from the RubiCrawler as seen in

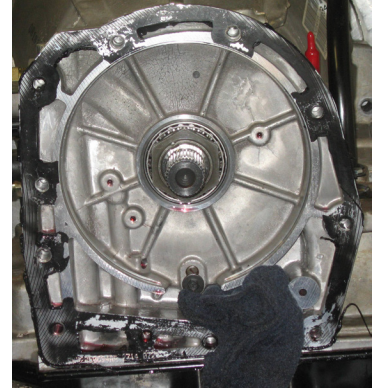

Figure 5: Rag Placement



Figure 6: Clean Transmission

SPECIAL NOTE: The components packaged in this kit have been assembled and machined for specific type of conversions. Modifications to any of the components will void any possible warranty or return privileges. If you do not fully understand modifications or changes that will be required to complete your conversion, we strongly recommend that you contact our sales department for more information. This instruction sheet is only to be used for the assembly of Advance Adapter components. We recommend that a service manual pertaining to your vehicle be obtained for specific torque values, wiring diagrams and other related equipment. These manuals are normally available at automotive dealerships and parts stores.

RUBICRAWLER JEEP JK with HD T/C CABLE (2007-2011)

- Figure 14* . Remove the rag from the transmission and discard the red plug.
- The RubiCrawler should be test fit into the vehicle by installing it without RTV to make sure the RubiCrawler flange face touches the transmission face completely. This is to insure that the output shaft is not too long. The product was designed for a standard output shaft stick-out, but the stick-out could vary which would cause a major problem. If you experience a problem, DO NOT proceed, call Advance Adapters. Steps 3 and 4, are time sensitive and should be completed in under 10 minutes.
 - Reclean the transmission face and the front face of the RubiCrawler using solvent. Apply an 1/8" bead of the supplied Chrysler (ATF+4 compatible) RTV to the RubiCrawler as shown in *Figure 15*.
 - Reinstall the O-ring as shown in *Figure 15*. This is very important for the RubiCrawler and Transmission lubrication circuits.**
 - Lift the RubiCrawler into place, rotate the output shaft until the splines line up and the RubiCrawler slides on, make sure it slides on by hand far enough to squish the RTV. Fasten the RubiCrawler with the 10 supplied 10 mm socket head cap screws using an 8 mm hex bit socket and the 10mm button head cap screw that bolts on under the shifter box using a 6 mm hex bit socket. Torque all bolts to 40 ft.-lbs. (See *Figure 16*)
 - Install the supplied RubiCrawler foot mount using the supplied 10 mm hex head bolts and washers. Torque to 40 ft.-lbs. (See *Figure 17*) Bolt the top half of the factory rubber mount assembly to the RubiCrawler foot mount and the bottom half of the rubber mount to the crossmember.
 - Lower the powertrain back down onto the crossmember and fasten the two halves of the rubber mount assembly together with the factory nuts.
 - Reattach the fuel line tab to the RubiCrawler fuel line bracket with the factory bolt.

NOTE: RubiCrawler Control Module (42R800), now is the best time to install it. Refer to the RubiCrawler Control Module installation instructions at this time.

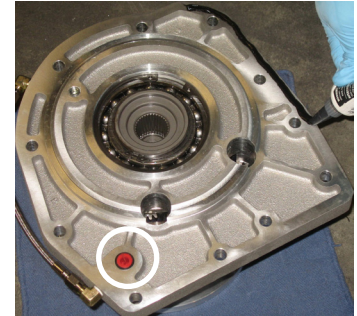

Figure 14: Plug/O-ring location

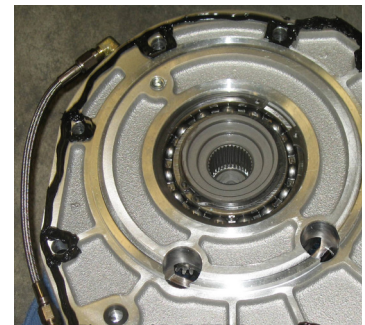

Figure 15: RTV Pattern

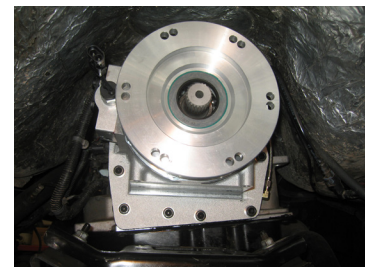

Figure 16: RubiCrawler Installed

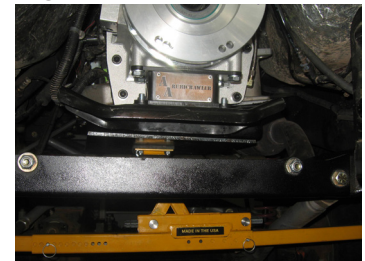

Figure 17: Install Supplied Foot Mount

SPECIAL NOTE: The components packaged in this kit have been assembled and machined for specific type of conversions. Modifications to any of the components will void any possible warranty or return privileges. If you do not fully understand modifications or changes that will be required to complete your conversion, we strongly recommend that you contact our sales department for more information. This instruction sheet is only to be used for the assembly of Advance Adapter components. We recommend that a service manual pertaining to your vehicle be obtained for specific torque values, wiring diagrams and other related equipment. These manuals are normally available at automotive dealerships and parts stores.

RUBICRAWLER JEEP JK with HD T/C CABLE (2007-2011)

RubiCrawler Shift Cable Installation:

1. Remove the 5/8" lock nuts and the 1/4"-28 nut from the in-cab (non bracketed) end of the supplied RubiCrawler shift cable and push it through the newly cut slit in the floor grommet making sure the cable is routed to the passenger side of the stock cable.
2. Bolt the RubiCrawler shifter bracket to the side of the RubiCrawler with the supplied 8 mm socket head cap screws and 1/4" washers using a 6 mm Allen wrench. (See Figure 18)
3. Verify that the RubiCrawler shift cable travels 1/8" past the heim joint stud for both high and low positions. Bolt the heim joint to the lever using medium strength thread locking compound and the supplied 1/4-28 BHCS. (See Figure 21)

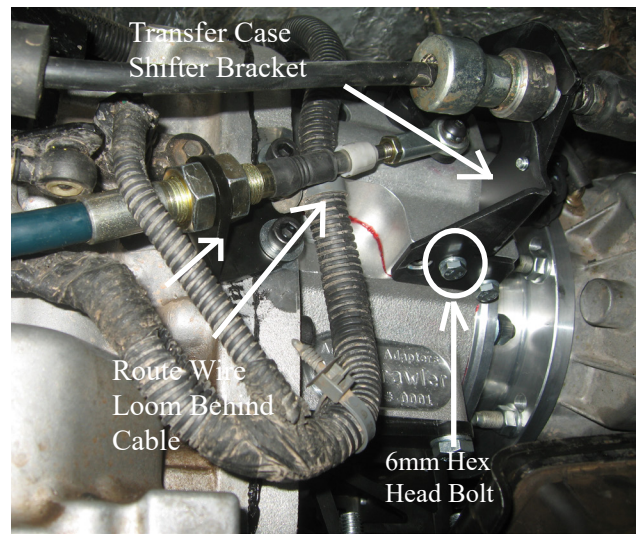

Figure 18: Shifter Bracket Installation

1. Install transfer case shifter bracket with supplied 6 mm hex head bolts and lock washers to the RubiCrawler shift housing. (See Figure 18)
2. Remove orange plastic retainer clip from transfer case shift cable and discard.
3. Lubricate the lip seal on the back of the RubiCrawler with ATF+4.
4. Retain the same clocking rotation as your stock transfer case. Shift the transfer case into any gear other than neutral. The RubiCrawler has a machined mark that designates the stock rotation hole set. Install the transfer case back into the vehicle by lifting it into place and rotating the rear yoke until the splines engage.
5. Use stubby 9/16" wrench to torque transfer case nuts to 25-30 ft.-lbs.
6. The shifter kits comes with a new shifter lever for the transfer case. The lever must be installed to achieve the proper throw on the linkage. Unfortunately, the NP241 Rocktrac transfer case design does not allow you access to the #40 torx bit without removing the transfer case front yoke (NP241 with the 2:72:1 low does not require the yoke to be removed). Once the yoke is removed and the lever bolt is removed, install the new lever on the transfer case with the supplied 8mm bolt and 1/4" flat washer.



The new cable can now start to be installed. First, the cable must be installed to the bracket using the large nuts on the cable as shown. Next, equip the new cable with a heim joint and tighten the jam nut. You can now install the cable up through the hole in the floorboard and into the cab.

Cable adjustment to transfer case:

SPECIAL NOTE: The components packaged in this kit have been assembled and machined for specific type of conversions. Modifications to any of the components will void any possible warranty or return privileges. If you do not fully understand modifications or changes that will be required to complete your conversion, we strongly recommend that you contact our sales department for more information. This instruction sheet is only to be used for the assembly of Advance Adapter components. We recommend that a service manual pertaining to your vehicle be obtained for specific torque values, wiring diagrams and other related equipment. These manuals are normally available at automotive dealerships and parts stores.

RUBICRAWLER JEEP JK with HD T/C CABLE (2007-2011)

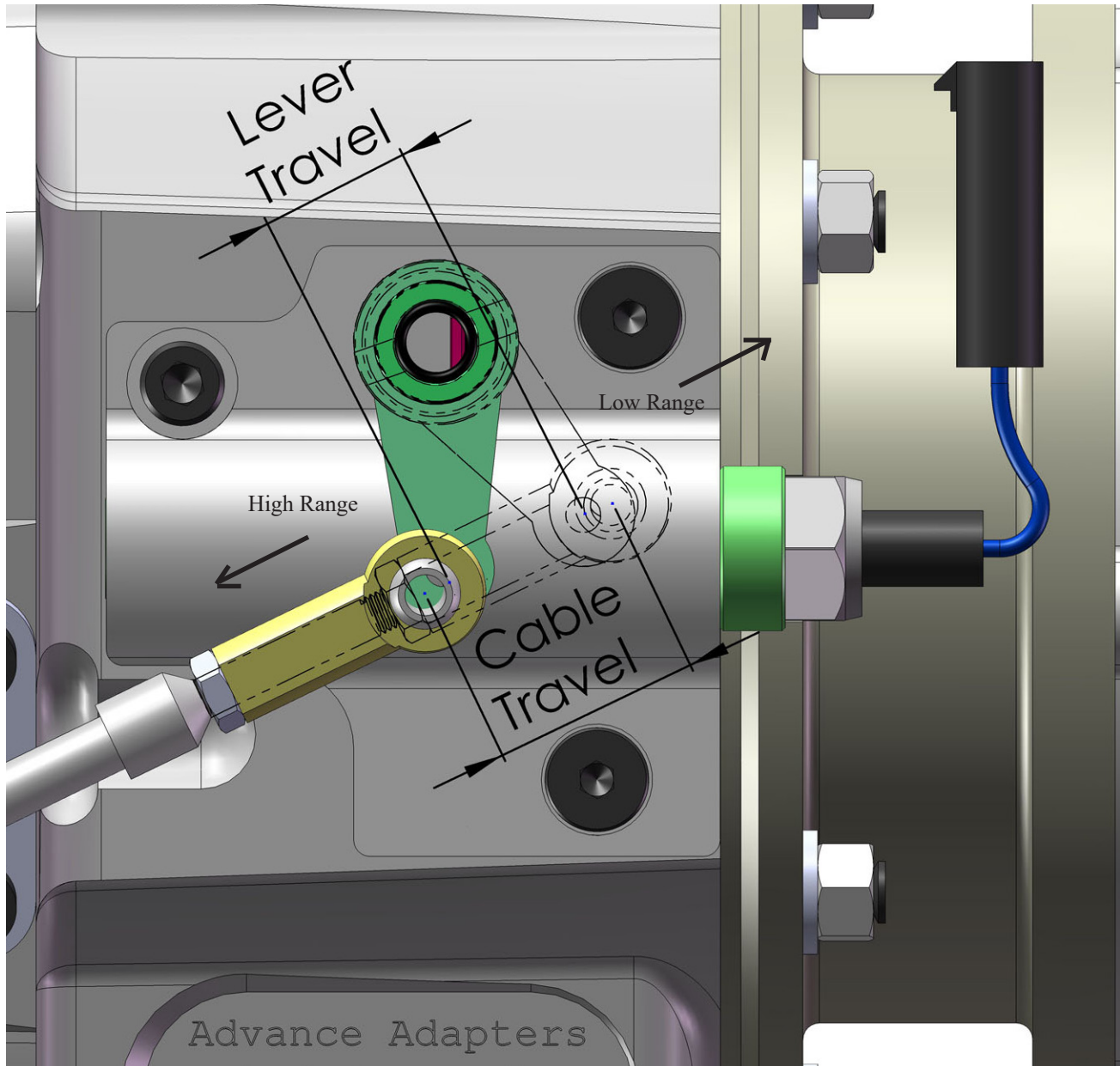

Figure 21: RubiCrawler cable shifter adjustment verification.
See Step 4 of the RubiCrawler Shift Cable Installation

SPECIAL NOTE: The components packaged in this kit have been assembled and machined for specific type of conversions. Modifications to any of the components will void any possible warranty or return privileges. If you do not fully understand modifications or changes that will be required to complete your conversion, we strongly recommend that you contact our sales department for more information. This instruction sheet is only to be used for the assembly of Advance Adapter components. We recommend that a service manual pertaining to your vehicle be obtained for specific torque values, wiring diagrams and other related equipment. These manuals are normally available at automotive dealerships and parts stores.

RUBICRAWLER JEEP JK with HD T/C CABLE (2007-2011)

NP241 Rocktrac transfer cases the heim is bolted to the outside of the shift lever with the 1/4"-20 x 1" bolt and lock nut. On the non-Rubicon NP241, the heim joint bolts to the outside of the shift lever with the addition of the 1/2" spacer between the heim joint and the T/C lever. Use the 1/4"-20 x 1-1/2" bolt and lock nut.

Adjust the linkage so that the heim joint travels approximately 1/8" past the lever in 2 high and 4 low.

On the Rubicon applications, reinstall the transfer case yoke. We recommend the use of black RTV silicone to the splines of the yoke (about a 1/4" bead) to prevent leakage. Install the new nut supplied in the kit and torque to 150 ft.-lbs.

7. Shift the transfer case into 2wd-high by pulling the transfer case shift lever towards the front of the vehicle.
8. Verify that the transfer case cable travels forward of the heim stud by 1/8"-3/16".
9. Shift transfer case into 4wd-low by pushing the transfer case shift lever towards the rear of the vehicle.
10. Verify that the transfer case travels 1/8- 3/16" farther rearward than the heim stud.
11. Secure the heim joint to the transfer case shift lever.
12. Reinstall the transfer case breather hose and wiring harness.
13. Reinstall drive shafts and skid plates.



LEVER MUST FIT TO THE T/C WITH THIS SIDE OUT.

Interior Installation:

2007-2011 JK NP241 t-case shifter adjustment

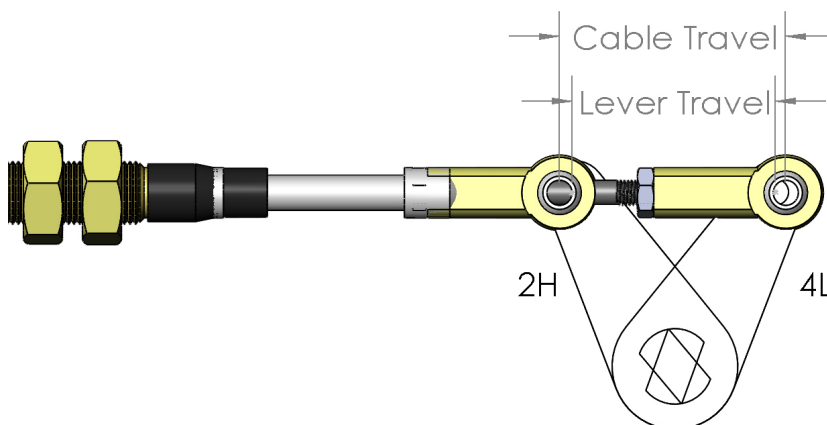

Adjust cable so that heim joint travels approximately 1/8" past lever hole in 2H and 4L.

SPECIAL NOTE: The components packaged in this kit have been assembled and machined for specific type of conversions. Modifications to any of the components will void any possible warranty or return privileges. If you do not fully understand modifications or changes that will be required to complete your conversion, we strongly recommend that you contact our sales department for more information. This instruction sheet is only to be used for the assembly of Advance Adapter components. We recommend that a service manual pertaining to your vehicle be obtained for specific torque values, wiring diagrams and other related equipment. These manuals are normally available at automotive dealerships and parts stores.

RUBICRAWLER JEEP JK with HD T/C CABLE (2007-2011)

1. Place the two supplied 1/4" washers on driver's rear mounting stud as shown in the picture. (See *Figure 23*)
2. Install the shifter base plate over the mounting studs and secure using the 4 OEM nuts. (See *Figure 24*)
3. Install 5/8" jam-nut onto cable. Remove cable barrel from the shifter pivot assembly and thread completely onto cable. Leave barrel finger tight. Thread heim joint entirely onto cable end and tighten 1/4" jam nut.
8. Bolt the cable retaining bracket to base plate with 2 supplied 1/4"-20 x 3/8" button head bolts. We recommend sliding the bracket completely forward in its slots, to maximize dash/knob clearance.
9. Shift the transfer case into 4wd-high and RubiCrawler into high range. This will grant access to insert the 1/4"-28 x 5/8" button head bolt through the heim joint, threading into RubiCrawler shift lever. (See *Figure 29*)
10. Tighten 5/8" jam nut against cable barrel.
11. Refer to the disassembly instructions to reinstall the console, dash panels, and seat .
12. Attach the transfer case knob mount to the drivers side lever with the supplied 1/4"-28 x 5/8" flat head bolts. Use medium strength Loctite and torque to 10 ft-lbs. Snap factory plastic knob to the knob mount.
13. Attach the RubiCrawler knob mount to the passenger side shift lever, also with 1/4"-28x 5/8" flat head bolts. Use medium strength Loctite and torque to 10 ft-lbs. Thread the 1/2"-13 jam nut and RubiCrawler knob onto knob mount tighten in correct orientation.

Transmission Fluid Re-Fill:

Caution: under filling or over filling can result in damage to your transmission. Only use Mopar approved, ATF+4 to refill the transmission.

1. Park on a flat surface and apply parking brake.
2. Start the engine and let the vehicle idle.
3. Apply the brakes and shift the transmission through all of the gears, then back to NEUTRAL and leave the vehicle idling.
4. Check the transmission fluid level with the dipstick. Using a clean funnel, add ATF+4 transmission fluid until the oil level is between the two holes marked "COLD". (Check to see if the transmission fluid level on the dipstick is even on both sides. If one side is noticeably higher than the other, the dipstick has picked up some fluid from the fill tube. Allow the fluid to drain down the transmission fill tube and recheck.
5. Now that the fluid level has been approximately achieved, drive the vehicle 5-10 miles making sure to manually shift the transmission through all gears.
6. Recheck the fluid level, with the transmission at operating temperature, vehicle idling on flat ground, the parking brake set, and the transmission in neutral. Add ATF+4 to raise the fluid level to a point between the two holes marked "HOT". Do this slowly so that the transmission fill tube has time to drain and gives accurate readings.

NOTE: For proper operation of the RubiCrawler, refer to the Shifting Procedure/Warranty paperwork and the yellow tag attached to the RubiCrawler case.



Figure 23: Washer Location



Figure 24: Install Shifter Base Plate

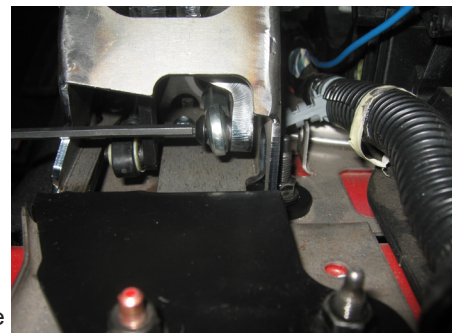

Figure 29: Install Heim Joint to RubiCrawler Shift Lever

RUBICRAWLER JEEP JK with HD T/C CABLE (2007-2011)

SHIFTING INSTRUCTIONS

Transfer Case Shifting: The transfer case can be shifted from two wheel drive to 4 wheel drive HIGH while the vehicle is moving. To shift the transfer case into four wheel drive LOW, you must shift the transmission to neutral and the vehicle speed must be below 2 mph. The transfer case can be shifted at a complete stop but it is easier to shift the unit when at a very slow roll.

RubiCrawler Shifting: The RubiCrawler must be shifted when the transmission is in neutral and the vehicle speed is less than 2 mph. The RubiCrawler can be shifted at a complete stop but it is easier to shift the unit when at a very slow roll. Do NOT try to force the shift levers as serious damage to the shifters or unit can occur.

Serious damage to the RubiCrawler can occur if the proper shifting instructions are not followed.

Shift Knobs and Shift Patterns

The shift knobs and patterns can be seen below and on the next page.



SPECIAL NOTE: The components packaged in this kit have been assembled and machined for specific type of conversions. Modifications to any of the components will void any possible warranty or return privileges. If you do not fully understand modifications or changes that will be required to complete your conversion, we strongly recommend that you contact our sales department for more information. This instruction sheet is only to be used for the assembly of Advance Adapter components. We recommend that a service manual pertaining to your vehicle be obtained for specific torque values, wiring diagrams and other related equipment. These manuals are normally available at automotive dealerships and parts stores.

RUBICRAWLER JEEP JK with HD T/C CABLE (2007-2011)

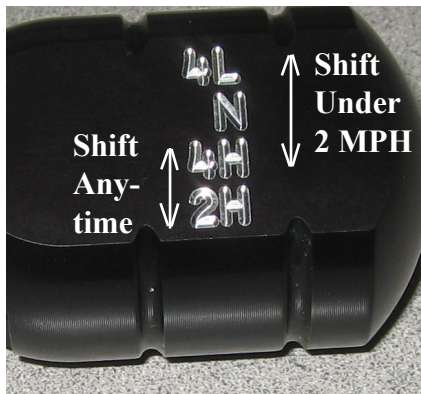

TJ Non-Rubicon Knob

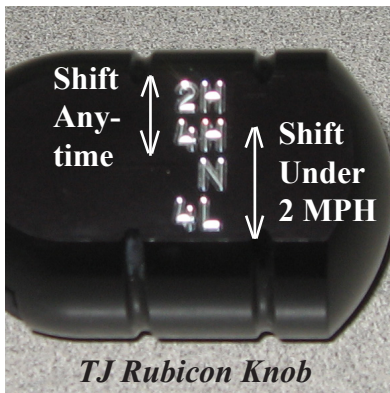

TJ Rubicon Knob

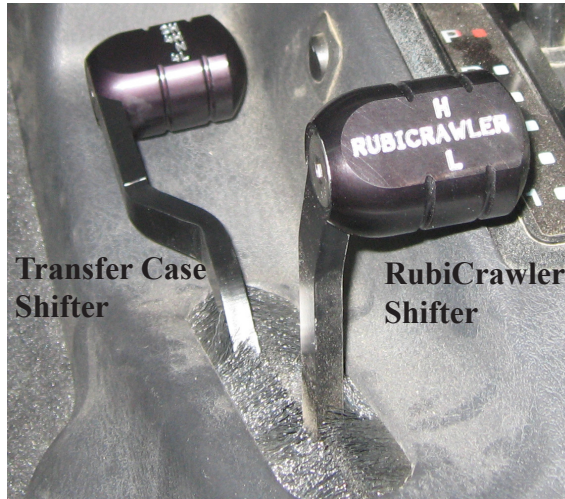

TJ Shift Knobs

Maximum Speed: The Rubi-Crawler should not be operated at engine speeds above 5000rpm when the transmission is in overdrive. This over speed condition will cause damage to the bearings and geartrain in the RubiCrawler, in addition to possible damage to other components in the vehicle.

ADVANCE ADAPTERS, INC. LIMITED WARRANTY

The RubiCrawler is guaranteed against defects in workmanship and materials for one year. This warranty begins from the date the unit is shipped from Advance Adapters. We log all units with a serial number at time of shipping. The warranty is void (as determined by Advance Adapters, Inc.) by misuse, abuse, improper maintenance or installation and or alterations to the product.

These guarantees do not cover any outside labor, shipping, towing, normal wear or any other unforeseen events that that may occur due to failure of a unit. Advance Adapters reserves the right to repair or replace any product.

Do not disassemble or attempt to repair the RubiCrawler as doing so will void the warranty, just return the product as further described below.

All returns must have a returned goods authorization (RGA#) prior to shipping the product, and returns are to be sent prepaid freight. Please call 1-800-350-2223 and the sales department can assist you.

Warranty will be voided if the proper transmission fluid levels are not maintained, if any transmission fluid other than ATF+4 is used, or the product has not been properly installed and instructions have not been followed.

SPECIAL NOTE: The components packaged in this kit have been assembled and machined for specific type of conversions. Modifications to any of the components will void any possible warranty or return privileges. If you do not fully understand modifications or changes that will be required to complete your conversion, we strongly recommend that you contact our sales department for more information. This instruction sheet is only to be used for the assembly of Advance Adapter components. We recommend that a service manual pertaining to your vehicle be obtained for specific torque values, wiring diagrams and other related equipment. These manuals are normally available at automotive dealerships and parts stores.