



4320 Aerotech Center Way  
Paso Robles, CA 93447  
Telephone: (800) 350-2223 Fax: (805) 238-4201  
PAGE 1 OF 4 Page Rev. Date: 07-08-20  
P/N: 712584A

## NV4500 TRANS. TO CUMMINS DIESEL REPLACING GETRAG 5 SPEED (4WD)

### KIT CONSISTS OF:

No.	Qty	Part No.	Description
1.	1	712584-BH	DODGE NV4500 BELLHOUSING/GETRAG REP.
2.	1	716047	CROSSMEMBER SUPPORT (4WD ONLY)
3.	1	716162	PILOT BUSHING
4.	2	724302	7/16" FLAT WASHER
5.	2	724303	7/16" LOCK WASHER
6.	2	724307	7/16"-14 x 1" H.H.C.S.
7.	4	725002	1/2" LOCK WASHERS
8.	4	725010	H.H.C.S. 1/2"-13 x 2"
9.	1	715540-BLK	BRACKET, GETRAG TO NV4500 1992-94
10.	1	715556	SHIFTER ROD, 12" UNBENT
11.	3	715650	BUSHINGS
12.	1	716140	BRAKE YOKE, 3/8" x 24"
13.	2	720005	COTTER PIN, 3/32" x 1-1/4"
14.	2	722523	FLAT WASHER, 1/4" PLT.
15.	2	723103	LOCK WASHER, 5/16" PLT.
16.	7	723122	FLAT WASHER, 5/16" PLT.
17.	2	723134	H.H.C.S. 5/16"-18 x 1-1/4"
18.	5	723704	LOCK WASHER, 3/8" PLT.
19.	1	723705	HEX NUT, 3/8"-24 PLATED
20.	5	723739	H.H.C.S. 3/8"-16 x 7/8" (GR 5)

### NOTE:

**This kit includes Part #715540 for 1992-94 vehicle with a gated type shifter.**

### TRANSMISSION MODIFICATIONS REQUIRED:

Prior to assembly, modification will be required to the front portion of the new NV4500 transmission.

The bearing retainer must be removed from the front of the 5 speed and shortened to a length that is 4.297" long. This can be done by using a hacksaw or engine lathe. By shortening the bearing retainer, this will prevent any interference with the hub on the clutch disc. Also, fit the bellhousing up to the back of the Cummings block to check flywheel and clutch assembly clearance on the inside of the new bellhousing. You may need to grind on the inside of the bellhousing for added clearance on the ring gear.

When assembling the transmission to the new bellhousing, **DO NOT USE** the bolts to draw the bellhousing into its final position. Make sure that the bellhousing will receive the transmission without any interference problems. This bellhousing is only compatible with the heavy-duty Dodge NV4500 transmission. This transmission will have a 1-1/4"-10 spline clutch disc that will be directly interchangeable with the original Getrag components.

SPECIAL NOTE: The components packaged in this kit have been assembled and machined for specific type of conversions. Modifications to any of the components will void any possible warranty or return privileges. If you do not fully understand modifications or changes that will be required to complete your conversion, we strongly recommend that you contact our sales department for more information. This instruction sheet is only to be used for the assembly of Advance Adapter components. We recommend that a service manual pertaining to your vehicle be obtained for specific torque values, wiring diagrams and other related equipment. These manuals are normally available at automotive dealerships and parts stores.

## NV4500 TRANS. TO CUMMINS DIESEL REPLACING GETRAG 5 SPEED (4WD)

Floorboard modifications for the shift lever will be required. There is a 4-1/2" difference between the Getrag and the NV4500 on the handle location. The hole in your floorboard will need to be located back on the floorboard roughly 4-1/2".

The original Getrag transmission used a seal on the backside of the main transmission case. They also used a seal on the front side of the transfer case inside the adapter housing. When using the new transmission, the seal on the transmission side has been eliminated and the only seal separating the two gear boxes is the original seal located on the front side of the transfer case. We have had numerous customers with the NP205 transfer case use the special NV4500 transmission fluid in both the transfer case and transmission in order to avoid any contamination between the two units. The original seal should provide ample protection from any contamination. We do not feel that it is necessary to use one common fluid for both gear boxes. We suggest monitoring the quality of the fluid in the transfer case in order to prevent any problems.

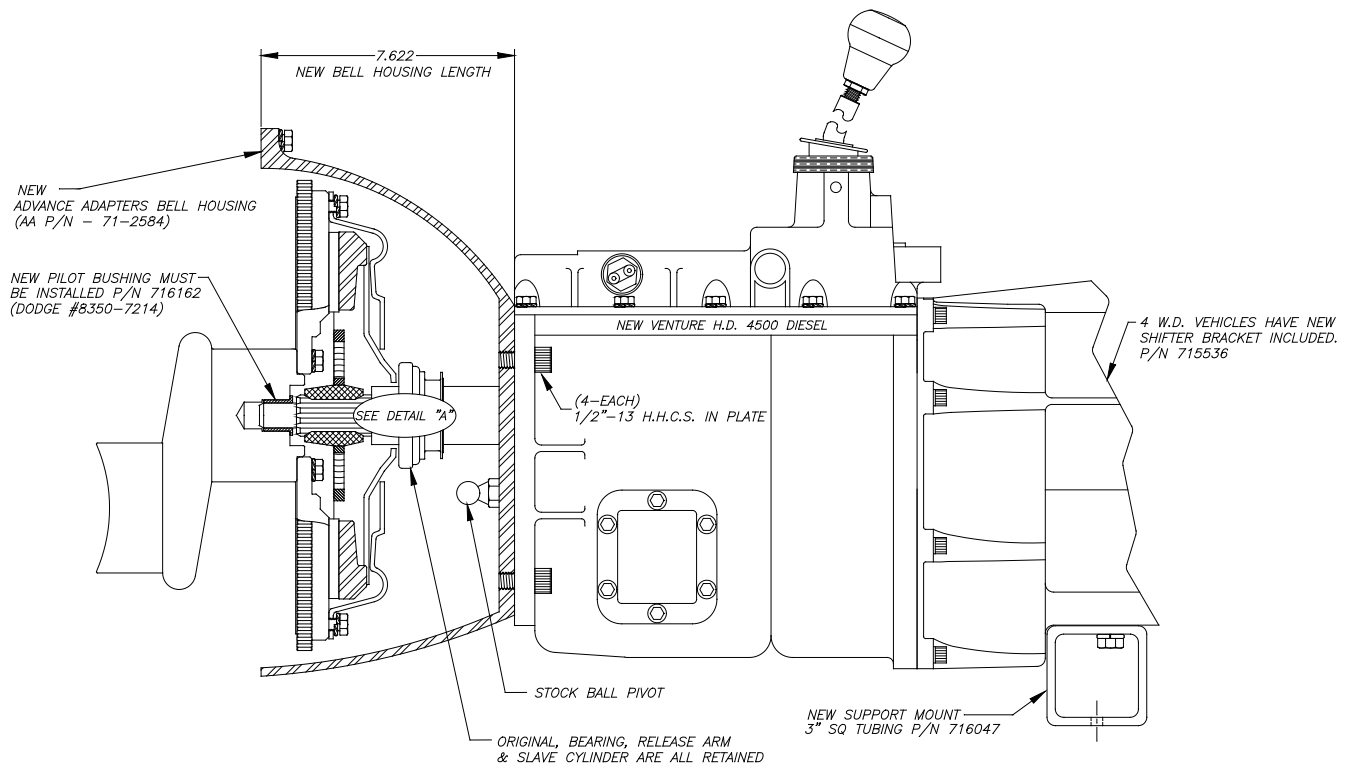

### Recommended Torque Ratings:

- Clutch Pressure Plate 5/16" Bolts-17 ft/lbs
- Clutch Pressure Plate 3/8" Bolts-30 ft/lbs

**SPECIAL NOTE:** The components packaged in this kit have been assembled and machined for specific type of conversions. Modifications to any of the components will void any possible warranty or return privileges. If you do not fully understand modifications or changes that will be required to complete your conversion, we strongly recommend that you contact our sales department for more information. This instruction sheet is only to be used for the assembly of Advance Adapter components. We recommend that a service manual pertaining to your vehicle be obtained for specific torque values, wiring diagrams and other related equipment. These manuals are normally available at automotive dealerships and parts stores.

## NV4500 TRANS. TO CUMMINS DIESEL REPLACING GETRAG 5 SPEED (4WD)

**NOTE:**

On some 1997 & newer transmissions we have found that some of the input shafts were not splined as far as they should be. This presents a problem in regards to the clutch hub bottoming out on the input shaft. If you are having a problem or feel you may have one of these transmissions with the short clutch spline, we offer a new shaft, Part No. 52-0228, or you could purchase an earlier input shaft from your Chrysler dealership. Refer to Photo #3 on page 3.

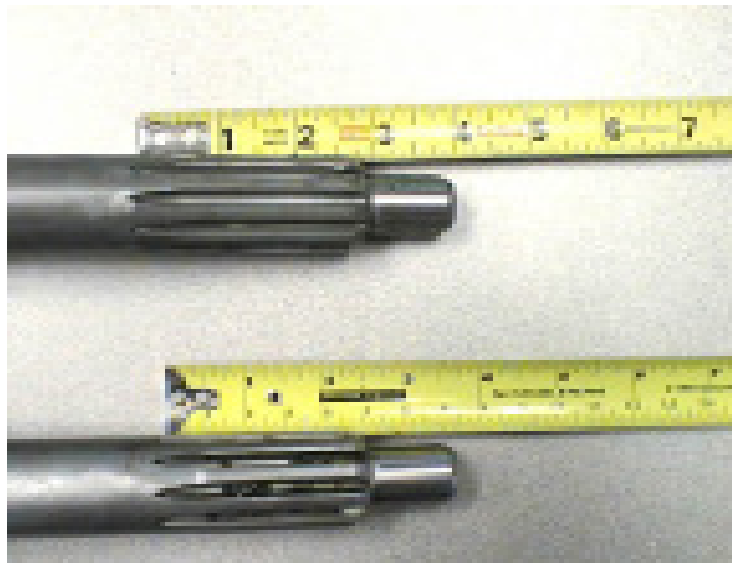
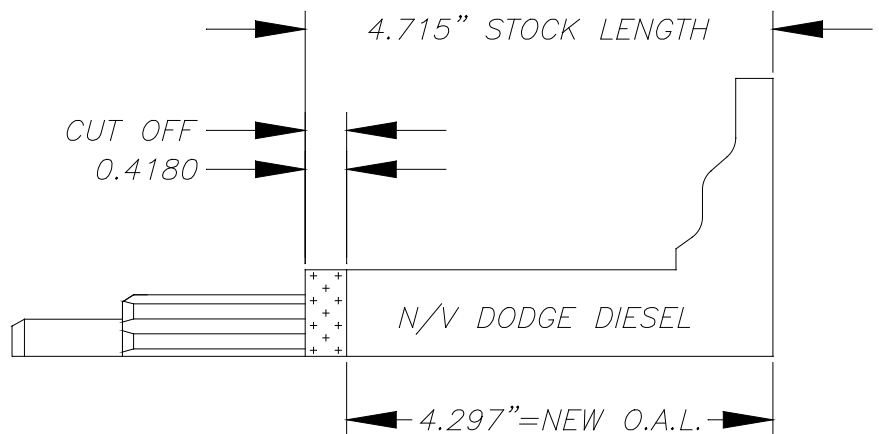

**The clutch spline on the lower input shaft is 1/4" to 3/8" shorter than the upper shaft. The splines should be 2-3/4" long to have the proper fit.**

**SPECIAL NOTE:** The components packaged in this kit have been assembled and machined for specific type of conversions. Modifications to any of the components will void any possible warranty or return privileges. If you do not fully understand modifications or changes that will be required to complete your conversion, we strongly recommend that you contact our sales department for more information. This instruction sheet is only to be used for the assembly of Advance Adapter components. We recommend that a service manual pertaining to your vehicle be obtained for specific torque values, wiring diagrams and other related equipment. These manuals are normally available at automotive dealerships and parts stores.

## NV4500 TRANS. TO CUMMINS DIESEL REPLACING GETRAG 5 SPEED (4WD)

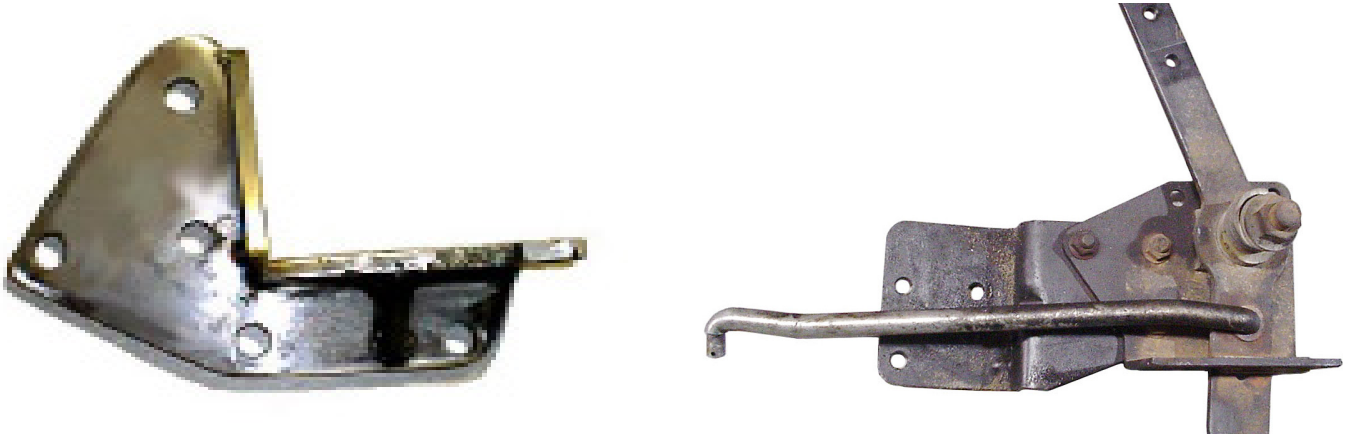

### INSTALLATION INSTRUCTIONS:

This transfer case linkage bracket is designed to replace a Getrag 5-speed with a NV4500. This bracket **ONLY** works with 1992 to 1994 gated type shifters. This type of shifter can also be identified by a 3/4" x 3-1/2" stud coming off the side of the bracket.

When installing this bracket, you must remove the original extension piece, P/N 5307690, before mounting the new bracket to the transmission.



The bracket mounts to the right side of the transmission (in the two back holes that mount the top cover on).

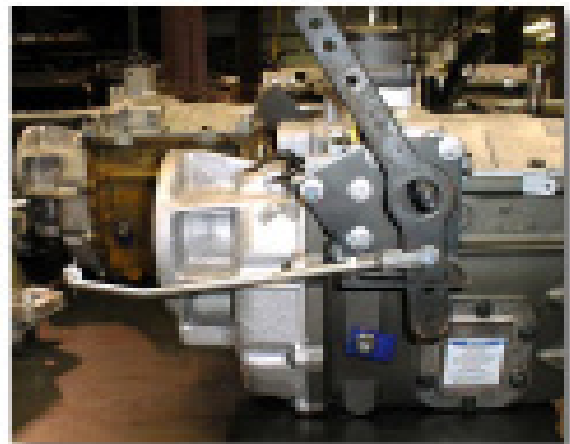

We have found in some cases, it may be necessary to bend the shifter rod to work with certain applications.

**SPECIAL NOTE:** The components packaged in this kit have been assembled and machined for specific type of conversions. Modifications to any of the components will void any possible warranty or return privileges. If you do not fully understand modifications or changes that will be required to complete your conversion, we strongly recommend that you contact our sales department for more information. This instruction sheet is only to be used for the assembly of Advance Adapter components. We recommend that a service manual pertaining to your vehicle be obtained for specific torque values, wiring diagrams and other related equipment. These manuals are normally available at automotive dealerships and parts stores.