



4320 Aerotech Center Way,
Paso Robles, CA 93446

Page 1 of 5
Rev Date 9-22-21

P/N 344025



ATLAS 4 SPEED PLANETARY CABLE SHIFTER FOR JEEP JK'S

KIT CONSISTS OF:

No.	Qty	Part No.	Description
1	1	302061	STICKER- ATLAS SHIFT KNOB
2	1	302083	KNOB - SHIFTER KNOB
3	1	303121	NUT-1/2-13 HX JAM BLACK ZINC
4	2	303305	BARREL- ATLAS SHIFTER CABLE
5	1	303309-2	CABLE-ATLAS SHIFTER 48" LENGTH 1" TRAVEL
6	1	303313	ROD END- FEMALE 1/4"-28
7	1	303341	BOLT- 1/4"-28 X 5/8" B.H.C.S.
8	1	305501	BRACKET- ATLAS 4SP CABLE MOUNT
9	2	303126	BUSHING- CABLE SHIFTER
10	1	340600	HOUSING- ATLAS 4SP CABLE SHIFTER
11	1	340601	PLATE- ATLAS 4SP SHIFTER HSG MNT
12	1	340602	RING- ATLAS SHIFT BOOT SINGLE STICK
13	1	340605	BOOT- SINGLE STICK
14	1	340608	STICKER- 4SP REDUCTION REV. PATTERN
15	2	340610	RETAINER- ATLAS CABLE SHIFTER BARREL
16	1	340613	1/4-28 Ball joint
17	1	340614	CLEVIS PIN
18	2	340615	BOLT- 1/4"-20 X 5/8" B.H.C.S.
19	1	340616	Cotter pin 3/32x 1 zinc
20	5	302453	1/4"-20 X 1" FHS
21	1	340618	LEVER- ATLAS 4SP CABLE SHIFTER FOR JK
22	2	722514	NYLON LOCKNUT 1/4"-20 Z
23	1	722523	1/4" USS FLAT WASHER PLTD.
24	4	722546	SCREW-TEK, HEX SELF DRILLING W/NEO #10- 16 X 1"
25	3	723730	S.H.C.S. 3/8"-16 X 1-1/4" (NEW BOLTS FOR ATLAS SHIFT BASE WHEN 305501 IS INSTALLED.)

SPECIAL NOTE:

We do not recommend flat towing vehicles with the Atlas 4 speed because of the planetary housing bearings and the additional needle bearing used in the Atlas. If you must flat tow your vehicle, than we recommend the drive shafts must be removed.

Note: we offer a reverse reduction sticker P/N 340608

Note: P/N 305501 gets installed over the Atlas shift rails before the cable shifter bracket is installed. When installing this bracket the Atlas must be shifted in low range (both rails into the case) for clearance when installing the 305501 bracket on the planetary housing. Also see page 13 of the 303035 JK shifter kit for additional installation notes.

NOTE ON SHIFTING: The planetary reduction portion of this box is a non-synchronized unit. YOU MUST COME TO A COMPLETE STOP BEFORE SHIFTING THE PLANETARY.

Manual Transmission Shifting Procedure: Stop vehicle. Shift planetary. If shift is unsuccessful, feather the clutch as you pull on the shift lever. The unit will slide easily into gear.

Automatic Transmission Shifting Procedure: Stop vehicle. Shift transmission to Neutral. Quickly shift the planetary lever. (If you pause, the transmission output shaft will accelerate while the planetary is between gears.) If the shift is not immediately successful, shut off the engine while still in neutral. Once engine is shut off, complete the shift. Then restart engine in neutral.

SPECIAL NOTE: The components packaged in this kit have been assembled and machined for specific type of conversions. Modifications to any of the components will void any possible warranty or return privileges. If you do not fully understand modifications or changes that will be required to complete your conversion, we strongly recommend that you contact our sales department for more information. This instruction sheet is only to be used for the assembly of Advance Adapter components. We recommend that a service manual pertaining to your vehicle be obtained for specific torque values, wiring diagrams and other related equipment. These manuals are normally available at automotive dealerships and parts stores.

ATLAS 4 SPEED PLANETARY CABLE SHIFTER FOR JEEP JK'S

BENCH ASSEMBLY:

1. Press pivot bushings (P/N 340612) into shifter handle (Part No. 340611), using a mallet.
2. Slide the barrel retainer (P/N 340610) over the long side of the barrel (P/N 303305).
3. Remove the 2nd jam nut & washer from the shift cable housing and thread it into the barrel, about halfway.
4. Thread the 1/4"-28 jam nut completely onto the inner cable and install the heim joint on to the cable end and then tighten the jam nut against the heim.
5. Seat the barrel into the shifter body and install the barrel retainer with the supplied button head socket cap screws (340615).
6. Slide the shifter handle (P/N 340618) up through bottom of the shifter body (P/N 340600).
7. Thread the heim joint (P/N 340613) into handle.
8. Insert the clevis pin (P/N 340614) and cotter pin (P/N 340616) for the pivot of the handle.
9. Leave the shift knob and jam nut off until the shifter is mounted in the vehicle.

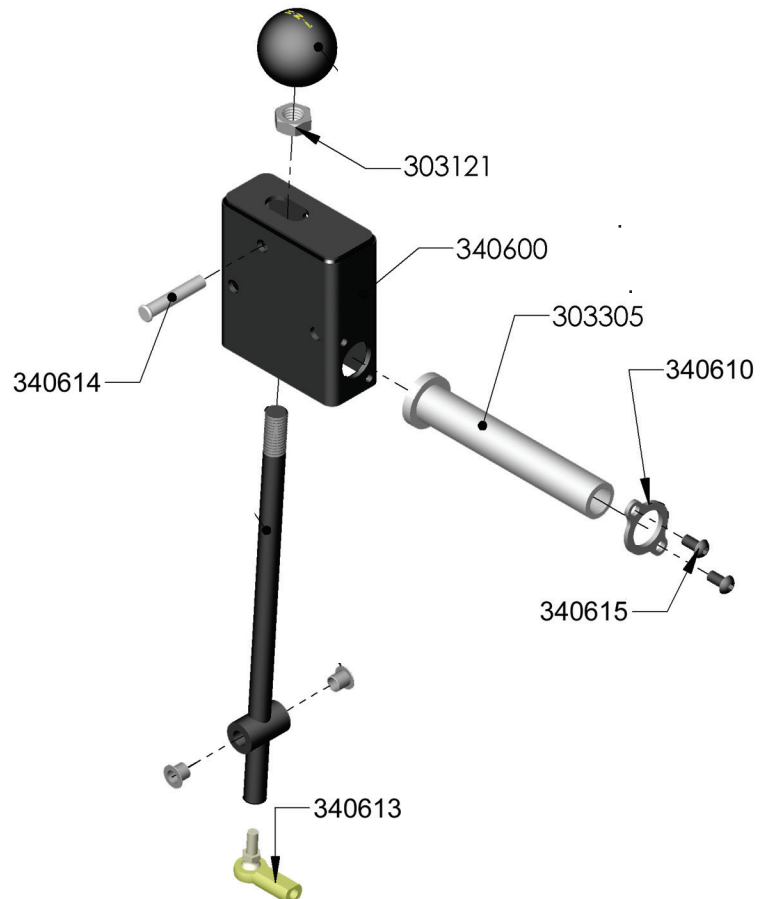

SPECIAL NOTE: The components packaged in this kit have been assembled and machined for specific type of conversions. Modifications to any of the components will void any possible warranty or return privileges. If you do not fully understand modifications or changes that will be required to complete your conversion, we strongly recommend that you contact our sales department for more information. This instruction sheet is only to be used for the assembly of Advance Adapter components. We recommend that a service manual pertaining to your vehicle be obtained for specific torque values, wiring diagrams and other related equipment. These manuals are normally available at automotive dealerships and parts stores.

ATLAS 4 SPEED PLANETARY CABLE SHIFTER FOR JEEP JK'S

CABLE ADJUSTMENT:

1. Move the handle back and forth within the shifter body to the ends of its travel. Verify that the handle does not contact either side of the shifter body. If it does not, proceed to step 2. If the handle is contacting the shifter body, loosen the button head set screws and the barrel jam nut. Rotate the barrel independently to adjust the handle position. Recheck for interference and repeat as necessary.
2. Move the shift knob so it bottoms out toward the shift cable. This is the low range position. Move the Pivot lever (shown in the photo) to the low range position. Adjust so the hole in the heim joint is behind the tapped hole in the lever by threading cable/shifter assembly in or out of the cable bracket.
3. Move the shift knob to the other end of its travel. Using the pivot lever, shift the planetary assembly to high range. Check that the hole in the heim joint is forward of the tapped hole in the lever. Adjust as necessary by the method in step 2. Repeat steps 2 & 3 until the pivot lever travel is centered within the cable shifter travel. Adjustment is complete.
4. Thread the 1/4"-28 x 5/8" Button Head Cap Screw (P/N 303341) through the heim joint into the pivot lever.

OIL FILLING:

After installing the sight tube per the instructions in the Atlas manual, add 2-1/2 quarts of included oil while still on the bench. We have found this to be easier while the unit is still out of the vehicle.

NOTE: We have included 3 quarts of oil with the new Atlas 4 speed transfer case. The new 4 speed should only be filled with 2-1/2 quarts of the 3 provided. If all three quarts are used it will cause the Atlas to vent out the extra fluid.

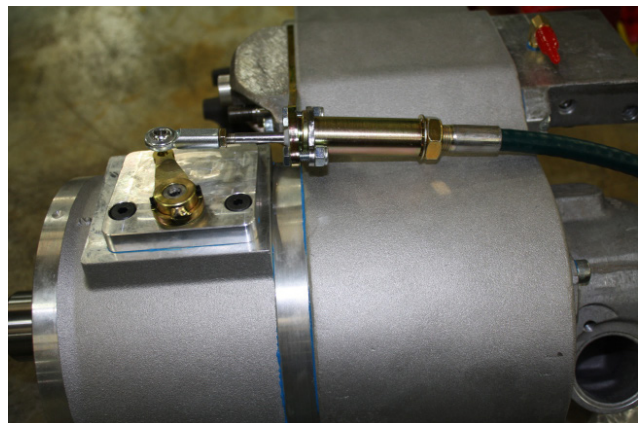
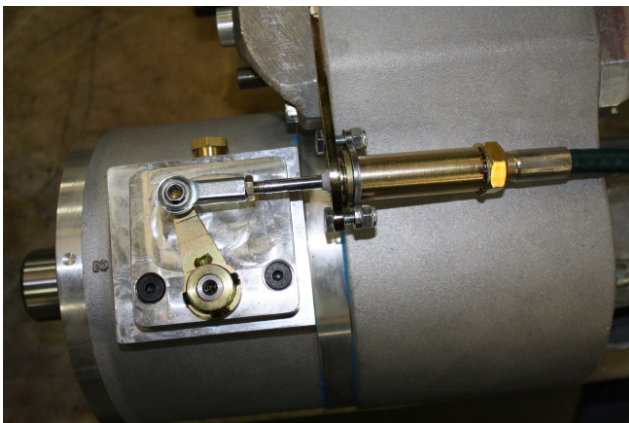

SPECIAL NOTE: The components packaged in this kit have been assembled and machined for specific type of conversions. Modifications to any of the components will void any possible warranty or return privileges. If you do not fully understand modifications or changes that will be required to complete your conversion, we strongly recommend that you contact our sales department for more information. This instruction sheet is only to be used for the assembly of Advance Adapter components. We recommend that a service manual pertaining to your vehicle be obtained for specific torque values, wiring diagrams and other related equipment. These manuals are normally available at automotive dealerships and parts stores.

ATLAS 4 SPEED PLANETARY CABLE SHIFTER FOR JEEP JK'S

IN VEHICLE ASSEMBLY:

1. Install the Atlas into the vehicle as per the instructions in the Atlas manual.
2. Route the cable so that it does not interfere with the driveshafts or other moving components. Also try to keep the cable away from the exhaust as much as possible.
3. Pull back the carpet on the driver's side and locate the body ribs on the left side of the tunnel area. We have found that locating the shifter approximately 4" down from the top of the tunnel and between the body ribs is a prime location for the 4 speed planetary or Rubicrawler shifter with an Atlas 2 speed. (Note: The installation shown has the two mounting screws facing forward in the Jeep and this is for a Rubicrawler. On an Atlas 4 speed the box would be mounted in the opposite direction with the two mounting screws toward the rear of the vehicle. This is important as to how the cable is configured to the two different boxes and the shift box configuration).
4. Take P/N 340601 mount plate, and use it as a template to modify the floorboard for the mounting holes and shift handle access. Note: The floor board just needs three holes drilled and a small oval slot for the handle.
5. Secure the shifter box to the underside of the floorboard by sandwiching the floorboard between the shifter box and the mount plate.
6. Slip the cable shift handle into the shifter box and through the floorboard and insert the clevis and cotter pin.
7. Install the boot ring into the boot and use the two self tapping screws (front and back) to retain it to the floorboard. Install the shift cable to the bottom of the shift handle using a 1/4-28 and install the jam nut and shift knob.



SPECIAL NOTE: The components packaged in this kit have been assembled and machined for specific type of conversions. Modifications to any of the components will void any possible warranty or return privileges. If you do not fully understand modifications or changes that will be required to complete your conversion, we strongly recommend that you contact our sales department for more information. This instruction sheet is only to be used for the assembly of Advance Adapter components. We recommend that a service manual pertaining to your vehicle be obtained for specific torque values, wiring diagrams and other related equipment. These manuals are normally available at automotive dealerships and parts stores.

ATLAS 4 SPEED PLANETARY CABLE SHIFTER FOR JEEP JK'S

The 4 speed shifter box need to be installed with the cable facing towards the front of the Jeep. The cable then gets routed over the transmission and back to the planetary shifter bracket.



SPECIAL NOTE: The components packaged in this kit have been assembled and machined for specific type of conversions. Modifications to any of the components will void any possible warranty or return privileges. If you do not fully understand modifications or changes that will be required to complete your conversion, we strongly recommend that you contact our sales department for more information. This instruction sheet is only to be used for the assembly of Advance Adapter components. We recommend that a service manual pertaining to your vehicle be obtained for specific torque values, wiring diagrams and other related equipment. These manuals are normally available at automotive dealerships and parts stores.