

## GM 4WD 32T TH400 AUTOMATIC TO NP205 TRANSFER CASE 1971-1984/85

### KIT CONSISTS OF:

No.	Qty	Part No.	Description
1.	1	51-3202	ADAPTER CASTING TH400
2.	1	*52-9600	GEAR NP205
3.	1	*52-9603	SHAFT NP205 LONG
4.	1	*716320	6210 INPUT BEARING
5.	1	*716467	SNAP RING
6.	1	716510	TRANSMISSION TO ADAPTER GASKET
7.	1	716572	NP205 GASKET
8.	1	716754	ADAPTER SEAL
9.	6	723701	HEX NUT 3/8"-16
10.	6	723704	3/8" LOCK WASHER
11.	6	723711	STUD BOLT 3/8"-16 x 2" LONG
12.	1	*340407	SNAP RING
13.	1	716471	6210 BEARING SNAP RING

This adapter kit is designed for the 4WD TH400 transmission with a 2.5" output shaft stickout. 2WD transmissions should use kit 50-3202

**\*ITEMS MUST BE ASSEMBLED BEFORE SHIPPING.**

NOTE:

This adapter kit should only be used when replacing a 4 speed manual or TH350 automatic that was connected to an NP205 transfer case. The transfer case will need to be machined for use with the larger bearing.

NP205 Machine Mods on 10 and 27 spline T/C's. The NP205 bearing bore must be machined to accept the larger 210 bearing of 3.543". This is an important part to get this new bore in the correct location. A machine shop should first index the transfer case bore to find center on the current bore, and then bore the larger bearing diameter. The new adapter plate will retain the bearing once the plate is installed.

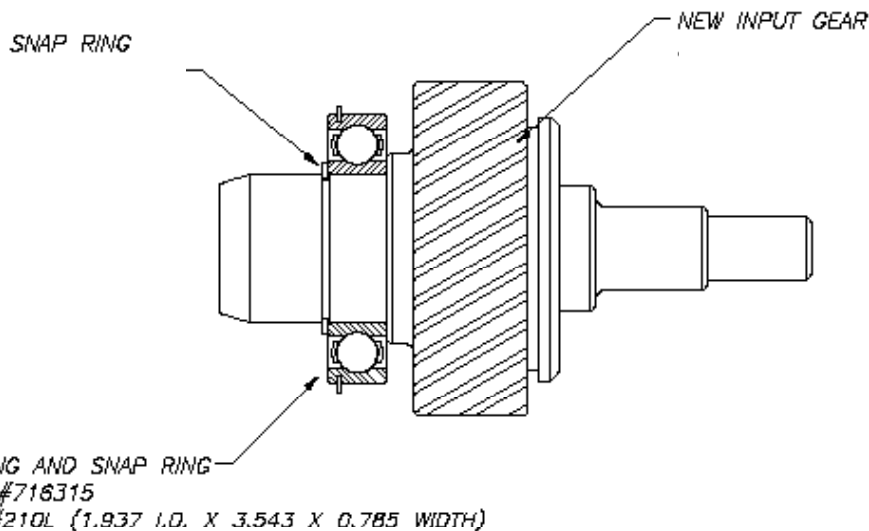

**SPECIAL NOTE:** The components packaged in this kit have been assembled and machined for specific type of conversions. Modifications to any of the components will void any possible warranty or return privileges. If you do not fully understand modifications or changes that will be required to complete your conversion, we strongly recommend that you contact our sales department for more information. This instruction sheet is only to be used for the assembly of Advance Adapter components. We recommend that a service manual pertaining to your vehicle be obtained for specific torque values, wiring diagrams and other related equipment. These manuals are normally available at automotive dealerships and parts stores.

## GM 4WD 32T TH400 AUTOMATIC TO NP205 TRANSFER CASE 1971-1984/85

When replacing a NP205 male input 10, 27, or 23 spline, the NP205 case will require machining for the larger input bearing bore.

Photos shown are of a Ford T/C. The installation on the new gear is the same on all models of T/C's

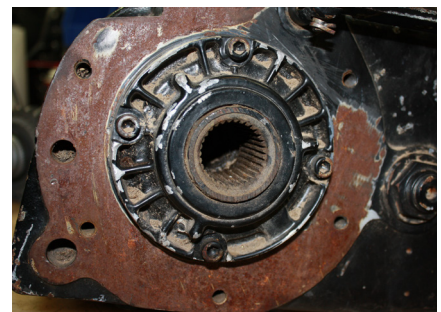
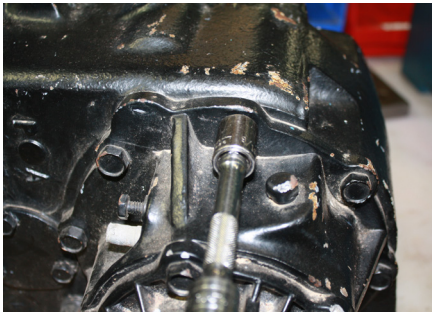

Remove the tailhousing bolts and front retainer bolts (if your transfer case has a front retainer). Shift the transfer case into 2WD high range and remove the tailhousing from the transfer case. Once the T/C output is removed, shift the T/C into low range which will release the slider. Remove the snap ring from the shaft to the bearing so the shaft and the bearing can be separated. This will allow the gear to drop downward and clear the shift fork.

Once the old gear and bearing are removed, clean the bore of the case and get ready to reassembly the new gear assembly.

**SPECIAL NOTE:** The components packaged in this kit have been assembled and machined for specific type of conversions. Modifications to any of the components will void any possible warranty or return privileges. If you do not fully understand modifications or changes that will be required to complete your conversion, we strongly recommend that you contact our sales department for more information. This instruction sheet is only to be used for the assembly of Advance Adapter components. We recommend that a service manual pertaining to your vehicle be obtained for specific torque values, wiring diagrams and other related equipment. These manuals are normally available at automotive dealerships and parts stores.

## GM 4WD 32T TH400 AUTOMATIC TO NP205 TRANSFER CASE 1971-1984/85



The new gear comes assembled with the outer bearing snap ring pulled off the bearing. From the back side of the transfer case install the gear and bearing into the case. The gear gets assembled at an angle to clear the shift fork. Slide the bearing and gear up to meet the case bore. The bearing should slide into the case bore enough to align everything, you can tap the back of the gear with a rubber mallet to get the bearing fully installed. Note the bearing should come out the front of the case and expose the snap ring groove.



The slider ring of the NP205 will need to be installed back onto the shift fork in low range and then the transfer case needs to be shifted into high range. During this procedure be careful of your fingers as you need to line the slider with the gear drive teeth. Once the gear and slider are supported together you will need to install the front bearing snap ring. This will retain the gear in the proper location in the case. The snap ring can be started in the bearing groove with your thumb and then just working it into place with your other hand until it spirals into place. With the rubber mallet tap the front of the gear assembly to set the bearing and snap ring against the case.

**SPECIAL NOTE:** The components packaged in this kit have been assembled and machined for specific type of conversions. Modifications to any of the components will void any possible warranty or return privileges. If you do not fully understand modifications or changes that will be required to complete your conversion, we strongly recommend that you contact our sales department for more information. This instruction sheet is only to be used for the assembly of Advance Adapter components. We recommend that a service manual pertaining to your vehicle be obtained for specific torque values, wiring diagrams and other related equipment. These manuals are normally available at automotive dealerships and parts stores.



P.O. Box 247, 4320 Aerotech Center Way  
Paso Robles, CA 93447  
Telephone: (800) 350-2223 Fax: (805) 238-4201  
PAGE 4 OF 5 Page Rev. Date: 2-11-20  
P/N: 50-3203

## GM 4WD 32T TH400 AUTOMATIC TO NP205 TRANSFER CASE 1971-1984/85

### GM TURBO 400 3 SPEED AUTOMATIC

The GM TH400 has a case length of 24-3/4", 13 bolts for holding the oil pan in position, and is available in 3 different engine to transmission bolt patterns. Make sure you have selected the proper TH400 for your particular engine. The rear side of the transmission case will have a hex shaped bolt pattern that uses 6 bolts. There are several various lengths of output shafts that these transmissions have been equipped with, and you will need the standard 4WD output shaft that protrudes 2-1/2" beyond the main case. The rear transmission support will now be located on the new adapter housing or, in some cases, on the transfer case.

This adapter kit includes a new input gear and bearing for the NP205 transfer case. This gear has a 32T internal spline that requires a larger bearing than most Chevy NP205 transfer cases. This gear is a stock GM item that was used on one ton vehicles only. The transfer case must be completely disassembled and the case machined to accommodate the new bearing furnished. Be sure to inspect the seal area provided in the adapter housing to make sure that it has the proper contact on the new sleeve and gear supplied.

This transfer case will require some machining to accept the larger bearing. We have provided a new gasket to be installed between the adapter plate and the transfer case to allow proper load heights on the bearing. This gasket is a stock GM component, and it will require some trimming to fit over the new larger bearing.

When installing the new transfer case adapter, make sure the new input gear and the output shaft do not bottom out. We have found on occasion that a transmission output shaft may be slightly longer than we have allowed; and when coupling into our new spud shaft, we find a small amount of interference. The adapter housing and spud shaft must be assembled to the back of the transmission without interference. **DO NOT FORCE THE NEW TAILHOUSING ONTO THE TRANSMISSION.** If assistance is needed, please feel free to call the number listed above.

All installations will require the use of a transmission cooler. The cooler can be either installed in the radiator or a remote location is acceptable. The transmission shift control can either be a Hurst floor mounted type shifter or sometimes the existing column shift can be modified on certain applications.

The vacuum modulator line will need to be shortened and rerouted to the right front side of the transmission. The original cooler lines and fitting will line up with the TH400 transmission. The original flexplate and converter can be retained. The transmission shift linkage can also be retained. The transmission dipstick must be from the TH400 application.

The TH400 kickdown operates off an electric signal. You will be required to purchase a late model gas pedal bracket, GM No. 1242101 and switch, GM No. 39772676.

The original transmission crossmember will need to be relocated on the frame rails due to the new transmission length.

**SPECIAL NOTE:** The components packaged in this kit have been assembled and machined for specific type of conversions. Modifications to any of the components will void any possible warranty or return privileges. If you do not fully understand modifications or changes that will be required to complete your conversion, we strongly recommend that you contact our sales department for more information. This instruction sheet is only to be used for the assembly of Advance Adapter components. We recommend that a service manual pertaining to your vehicle be obtained for specific torque values, wiring diagrams and other related equipment. These manuals are normally available at automotive dealerships and parts stores.

## GM 4WD 32T TH400 AUTOMATIC TO NP205 TRANSFER CASE 1971-1984/85

**NOTE!**  
THIS KIT WILL NORMALLY REQUIRE DRIVE LINE MODIFICATION.

<b>KIT NO. 50-3202</b>	
TH400 CASE LENGTH:	24.250"
ADAPTER (TH400):	4.000"
OVERALL LENGTH:	28.250"

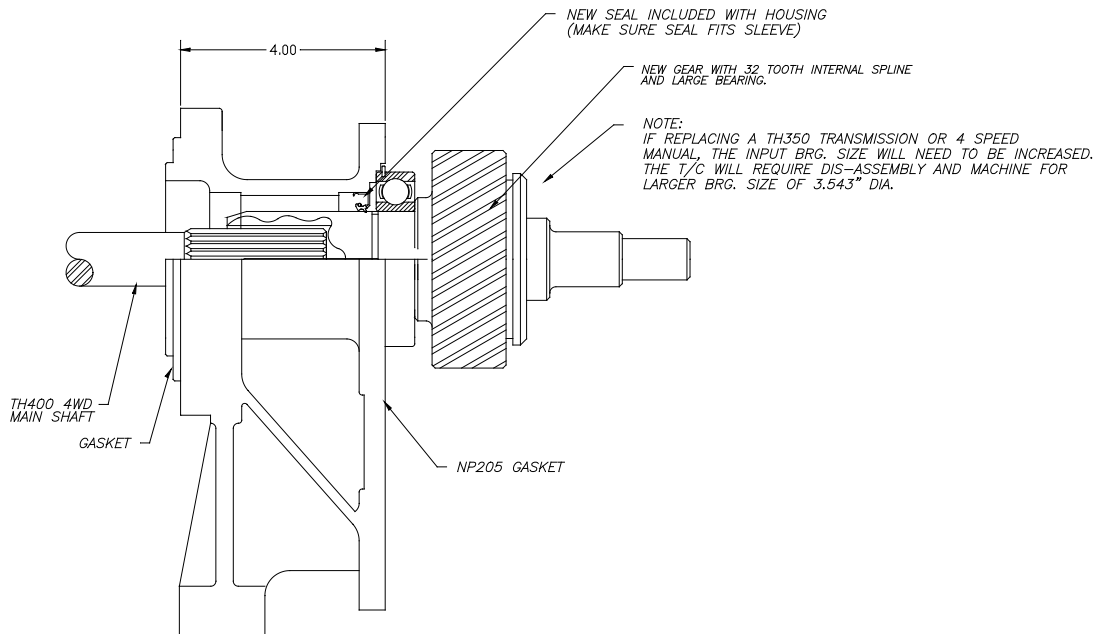

**SPECIAL NOTE:** The components packaged in this kit have been assembled and machined for specific type of conversions. Modifications to any of the components will void any possible warranty or return privileges. If you do not fully understand modifications or changes that will be required to complete your conversion, we strongly recommend that you contact our sales department for more information. This instruction sheet is only to be used for the assembly of Advance Adapter components. We recommend that a service manual pertaining to your vehicle be obtained for specific torque values, wiring diagrams and other related equipment. These manuals are normally available at automotive dealerships and parts stores.