



P.O. Box 247, 4320 Aerotech Center Way  
 Paso Robles, CA 93447  
 Telephone: (800) 350-2223 Fax: (805) 238-4201  
 PAGE 1 OF 3 Page Rev. Date: 10-05-18  
 P/N: 50-2402

## GM TRUCK 4SP MODEL SM420 TO JEEP & SCOUT DANA 18/20

### KIT CONSISTS OF:

No.	Qty	Part No.	Description
1.	1	51-1201	CASTING
2.	1	52-1401	29th x 6spl. 2.46:1 INPUT GEAR
3.	1	52-4700	SPUD SHAFT
4.	1	716224	MOUNT BLOCK
5.	1	716453	SNAP RING
6.	1	716454	SET COLLAR
7.	1	716508	GASKET (GM #384-9472)
8.	1	716568	GASKET
9.	8	723722	H.H.C.S. 3/8"-16 x 1-1/4" LG
10.	2	724342	F.H.S.C.S. 7/16"-14 x 2-1/2
11.	2	724351	7/16"-14 x 1/2" SET SCREW
12.	1	728701	NYLON LOCK NUT

### OPTIONAL ITEMS:

Qty	Part No.	Description
1	716003	CROSSMEMBER MT
1	716302	SEAL BRG.
1	716001 or	
	716002	BEARING RET.
1	716009	FRONT YOKE

\*20 Degree pressure angle gear:  
 Model 18 transfer cases with 2.46:1,  
 w/ T14 transmission, 1 1/4" intermediate shaft  
**CJ with Buck V6 (68-71)**  
 Drive gear# 18-8-50 (947382) ---29 tooth x 10 spline  
 Intermediate Gear # 18-5-9 (809293) ---39 tooth x 18 tooth  
 \*\*Requires AA part # 52-1401  
 18-8-23 (809297) ----29 tooth x 6 spline (**SUPPLIED IN KIT**)

17 Degree pressure angle gear:  
 Model 18 transfer cases with 2.03:1,  
 w/ T14 transmission, 1 1/4" intermediate shaft  
**Jeepster/CJ (67-74) models 18/20**  
 Drive gear# 18-8-49 (947339) ---26thx10sp.  
 Intermediate Gear# 18-5-16(946786) 34thx20th  
**(Special order gear)**

**SPECIAL NOTE:** The components packaged in this kit have been assembled and machined for specific type of conversions. Modifications to any of the components will void any possible warranty or return privileges. If you do not fully understand modifications or changes that will be required to complete your conversion, we strongly recommend that you contact our sales department for more information. This instruction sheet is only to be used for the assembly of Advance Adapter components. We recommend that a service manual pertaining to your vehicle be obtained for specific torque values, wiring diagrams and other related equipment. These manuals are normally available at automotive dealerships and parts stores.



P.O. Box 247, 4320 Aerotech Center Way  
Paso Robles, CA 93447  
Telephone: (800) 350-2223 Fax: (805) 238-4201  
PAGE 2 OF 3 Page Rev. Date: 10-05-18  
P/N: 50-2402

## GM TRUCK 4SP MODEL SM420 TO JEEP & SCOUT DANA 18/20 SPUD DSGN

### GM & CHEVY SM420 TRUCK 4 SPEED 1948-1967:

This transmission can be identified by a case length of 10-1/2". The casting numbers on the side of the case should be GM3761930 or GM3813389. The transmission has a shift cover that bolts over the top of the transmission that has a shift cover part number of GM591568. The P.T.O. opening is on the left hand side of the main case and the transmission has a non-synchro first gear.

The transmission you select can either be disassembled and machined for a snap ring that will retain the rear main bearing, or the new set collar we supply in the adapter kit can be used in place of the snap ring. If this set collar is installed properly, it will do the same job as the snap ring. Make sure the collar and the clamp screw secure the shaft from any forward movement. The drawing will illustrate the dimensional data for installation of a groove that must be cut into the shaft for holding the rear bearing in position. There are a few stock applications where this snap ring will already be in place and the transmission will not need the new snap ring or set collar.

The right side of the main case will need to be ground off for clearance of the front output yoke on certain installations. For early Jeeps with the Dana 18 and the larger yoke, we do offer a smaller front T/C yoke kit 716009. We recommend a trial fit with your transfer case and front output yoke so that any modifications that may be required can be done before final installation into the vehicle. This is also a good time to set up the shifter linkage for the transfer case controls.

The early Chevy truck 4 speeds were equipped with the small front bearing retainer that is 4.686" in diameter and must be used with either early truck bellhousings or late model car-type bellhousings. The late model truck bellhousings all use a 5-1/8" retainer size that will not be compatible with this transmission.

Advance Adapters changed the design of these SM420 kits to incorporate a spud shaft design in 1988. Prior to this time, we manufactured a completely new main shaft for all SM420 transmission conversions.

This adapter housing has two holes that will need to be plugged with the two set screws provided. Thread Lock or RTV blue silicone is recommended when installing the set screws to prevent leakage. These castings are designed for Toyota Land Cruisers and Jeep applications. You will only plug the holes on Jeep applications.

<b>First Gear</b>	<b>7.05</b>
<b>Second Gear</b>	<b>3.57</b>
<b>Third Gear</b>	<b>1.70</b>
<b>Fourth Gear</b>	<b>Direct</b>

**SPECIAL NOTE:** The components packaged in this kit have been assembled and machined for specific type of conversions. Modifications to any of the components will void any possible warranty or return privileges. If you do not fully understand modifications or changes that will be required to complete your conversion, we strongly recommend that you contact our sales department for more information. This instruction sheet is only to be used for the assembly of Advance Adapter components. We recommend that a service manual pertaining to your vehicle be obtained for specific torque values, wiring diagrams and other related equipment. These manuals are normally available at automotive dealerships and parts stores.

## GM TRUCK 4SP MODEL SM420 TO JEEP & SCOUT DANA 18/20 SPUD DSGN

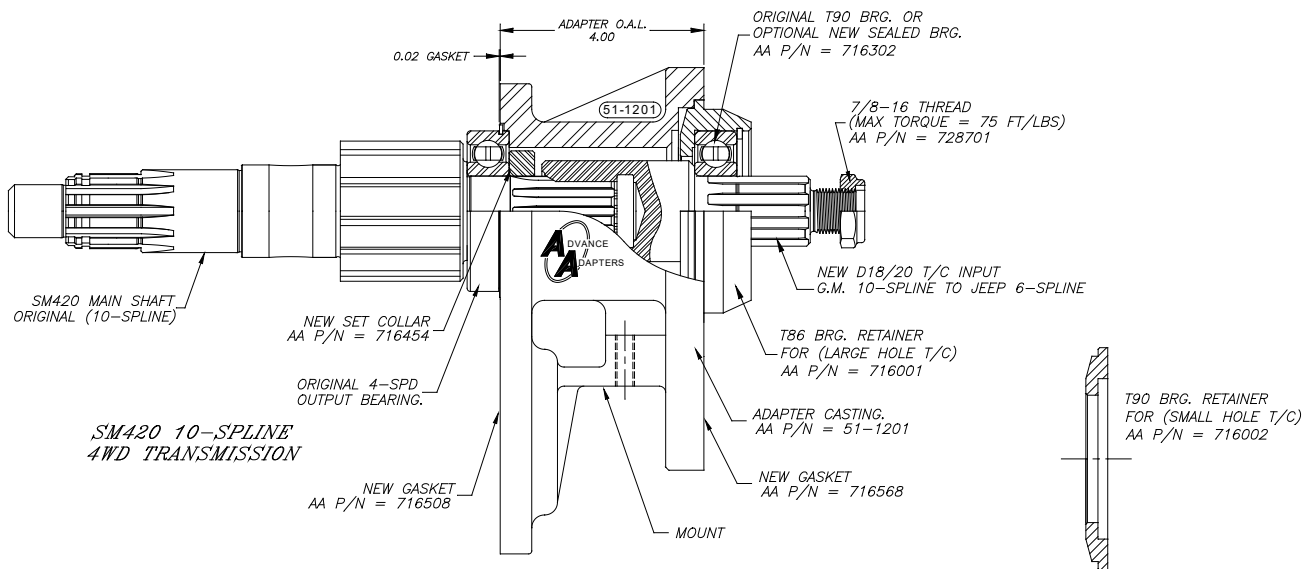

**NOTE:**

*On Jeep applications these two holes must be plugged with the two set screws provided to prevent leakage. Using RTV blue silicone or thread lock is recommended.*



**SPECIAL NOTE:** The components packaged in this kit have been assembled and machined for specific type of conversions. Modifications to any of the components will void any possible warranty or return privileges. If you do not fully understand modifications or changes that will be required to complete your conversion, we strongly recommend that you contact our sales department for more information. This instruction sheet is only to be used for the assembly of Advance Adapter components. We recommend that a service manual pertaining to your vehicle be obtained for specific torque values, wiring diagrams and other related equipment. These manuals are normally available at automotive dealerships and parts stores.