



P.O. Box 247, 4320 Aerotech Center Way  
Paso Robles, CA 93447  
Telephone: (800) 350-2223 Fax: (805) 238-4201  
PAGE 1 OF 3 Page Rev. Date: 03-21-22  
P/N: 50-9901

## Jeep JL & JT Manual 6 speed (D478) to Atlas

### KIT CONSISTS OF:

No.	Qty	Part No.	Description
1	51-9900	850RE	8-Speed AT & DODGE 8HP870 8-Speed TO ATLAS
1	52-9902		SHAFT- JEEP 43 FEMALE X JEEP 23 MALE
1	716308		SEALED BEARING 209RS
1	716450		SNAP RING (T350 & T400)
1	716456		TRUE ARC SNAP RING

**Jeep JL, D478 manual 6 speed to Atlas 2sp:** The manual transmission used in the JL will require the same adapter housing as the automatic with the same shifter components [P/N 50-9901](#). The Jeep JL with the manual 6 speed is coupled to a Magna transfer case. This is the first year Jeep went away from its standard circular bolt pattern when coupling these two gear boxes. So this required us to manufacture a new adapter housing to couple the Atlas to the manual transmission. [P/N 50-9901](#) adapts to a Atlas 23 spline standard input. The 7.75" adapter also provides the needed length to keep the transmission close to the stock location.

We offer a new yoke to retain the stock GKN driveshafts [P/N AFJL](#). The adapter puts the Atlas in a similar location as factory, allowing you to retain the factory driveshafts. These yokes can be swapped out for any Spicer yoke down the road, but it now allows the Jeep equipped Atlas to be back on the road within a day. The complete install of the transfer case is approximately 6 hours and the shifter 1 to 2 hours. The pre-configured unit we offer comes complete with the parts listed above. The Atlas is built with a **23 spline standard input**.

**SPECIAL NOTE:** The components packaged in this kit have been assembled and machined for specific type of conversions. Modifications to any of the components will void any possible warranty or return privileges. If you do not fully understand modifications or changes that will be required to complete your conversion, we strongly recommend that you contact our sales department for more information. This instruction sheet is only to be used for the assembly of Advance Adapter components. We recommend that a service manual pertaining to your vehicle be obtained for specific torque values, wiring diagrams and other related equipment. These manuals are normally available at automotive dealerships and parts stores.

## Jeep JL & JT Manual 6 speed (D478) to Atlas

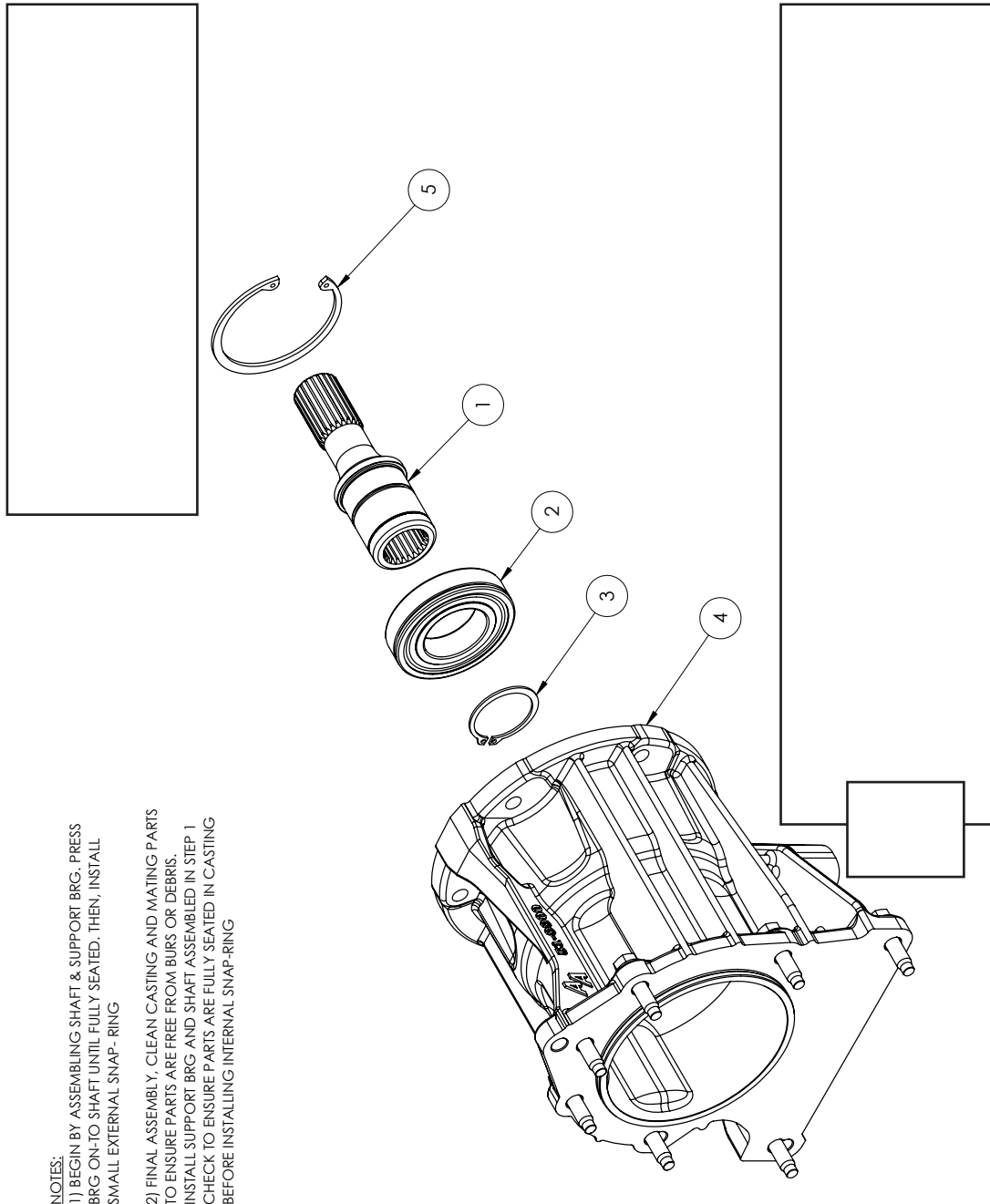

- NOTES:
- 1) BEGIN BY ASSEMBLING SHAFT & SUPPORT BRG. PRESS BRG ON-TO SHAFT UNTIL FULLY SEATED. THEN, INSTALL SMALL EXTERNAL SNAP-RING
  - 2) FINAL ASSEMBLY. CLEAN CASTING AND MATING PARTS TO ENSURE PARTS ARE FREE FROM BURRS OR DEBRIS. INSTALL SUPPORT BRG. AND SHAFT ASSEMBLED IN STEP 1. CHECK TO ENSURE PARTS ARE FULLY SEATED IN CASTING BEFORE INSTALLING INTERNAL SNAP-RING

**SPECIAL NOTE:** The components packaged in this kit have been assembled and machined for specific type of conversions. Modifications to any of the components will void any possible warranty or return privileges. If you do not fully understand modifications or changes that will be required to complete your conversion, we strongly recommend that you contact our sales department for more information. This instruction sheet is only to be used for the assembly of Advance Adapter components. We recommend that a service manual pertaining to your vehicle be obtained for specific torque values, wiring diagrams and other related equipment. These manuals are normally available at automotive dealerships and parts stores.

Removed the stock transfer case. Support the stock drivetrain up by the transmission as you will need to remove the transmission crossmember and skid pan. After the skid pan is removed, you should be able to remove the driveshafts from the stock transfer case. If retaining the stock driveshafts, these can be left connected to the axles.

Remove the crossmember and then unbolt and remove the transfer case. Note: If you are able to lower the rear side of the drivetrain a bit, it will provide better access to the transfer case to transmission bolts. The stock transfer case shifter linkage also needs to be removed.

Install the new adapter housing using the factory bolts. We recommend not connecting the crossmember back to the frame until the Atlas is installed. The bolts that are closest to the floorboard are hard to tighten if the drivetrain is back in the stock position.

Note: The stock transfer case breather (shown in the bottom left photo) need to be removed and installed on the Atlas. The Atlas is shipped with a red cap that covers the elbow that the breather should be connected to.

